

Compact Cladding Cell

HMI-T21



High-end cladding system combined on an extremely compact platform.

High-precision motion axes and the outstanding features of the HMI-T21 system controller enable cladding of a wide range of bore geometries with perfect welding results.

FEATURES

- For components with a bore diameter from 25 mm (0.98 inch)
- **SpeedClad 2.0** compatible - up to 3x higher cladding performance compared to conventional TIG hotwire welding processes
- High-precision torch and component positioning for perfect welding results
- One power supply for the entire system
- Optional with protective curtains

HMI-T21 – THE NEW CONTROLLER GENERATION

- **21" touch screen** user interface
- **Multi-user accounts** with individual permissions
- **Intelligent functions** such as „X-Ray View“, 3D Component Editor, Weld Editor, Bore-to-Bore Advanced, real-time actual value monitoring, etc.



Component data	
Max. component height by torch working length = 1m [39.37 in] (* with option: height extension)	1400 mm [55.11 in] 1900 mm* [74.80 in*]
Min. bore diameter	25 mm [0.98 in]
Max. outside diameter	1000 mm [39.37 in]
Max. weight	2500 kg [5511 lbs]

Technical data

Technical data	
Mains voltage	400V (L1/L2/L3/N/PE), 50/60 Hz
Power consumption max.	48 kVA
Prefuse type	3x 63 A
Ambiant temperature	5 - 40 °C (41 - 104 °F)
Humidity	max. 50% (40 °C / 104 °F)

	Dimensions									
	A mm [inch]	B mm [inch]	C mm [inch]	D mm [inch]	E mm [inch]	F mm [inch]	G min/max mm [inch]	H min/max mm [inch]	I (max*) mm [inch]	Total weight kg [lbs]
Standard height	3000 [118.11]	1922 mm [75.66]	4098 [161.33]	2554 [100.55 in]	4223 [166.25]	4636 [182.51]	2064,5 / 3564,5 [81.27 / 140.33]	467 / 1767 [18.38 / 69.56]	1497 [58.93]	3615 [7969,711]
With height extension	3000 [118.11]	1922 mm [75.66]	4098 [161.33]	2554 [100.55]	4723 [185.94]	5136 [202.20]	2564,5 / 4064,5 [100.96 / 160.01]	467 / 1767 [18.38 / 69.56]	1997 [78.62]	3705 [8168.12]

1



OPTIONAL HEIGHT EXTENSION

When using the optional height extension, the value **E, F, G, I,** and the maximum component height change by +500 mm [19.68 in].

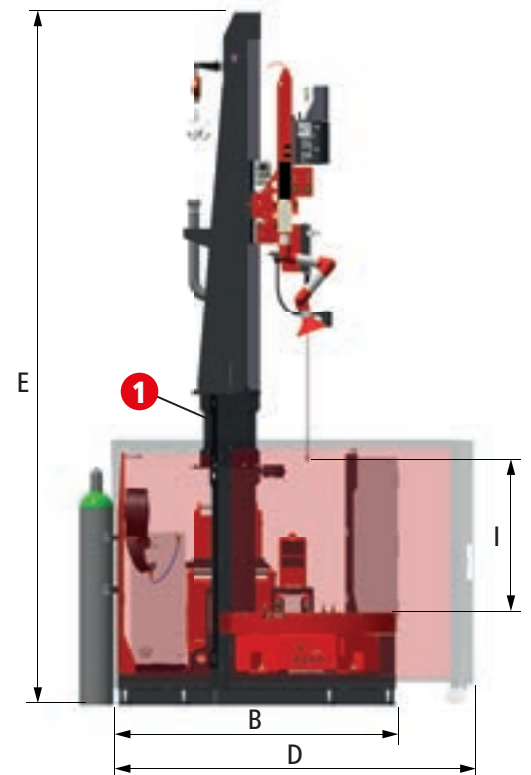
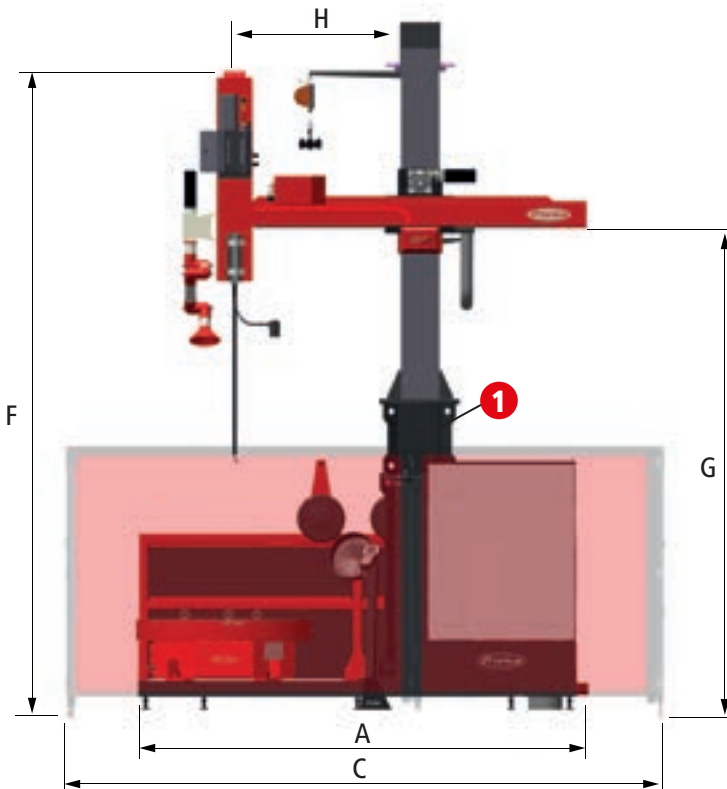

* Torch working length = 1 m (39.37 inch)